

HF

- ✓ Horizontal moulding to take maximum care of the dough
- ✓ Strong pace
- ✓ Silent (-65dB)
- ✓ Stainless steel exterior

Up to 1800 pieces an hour

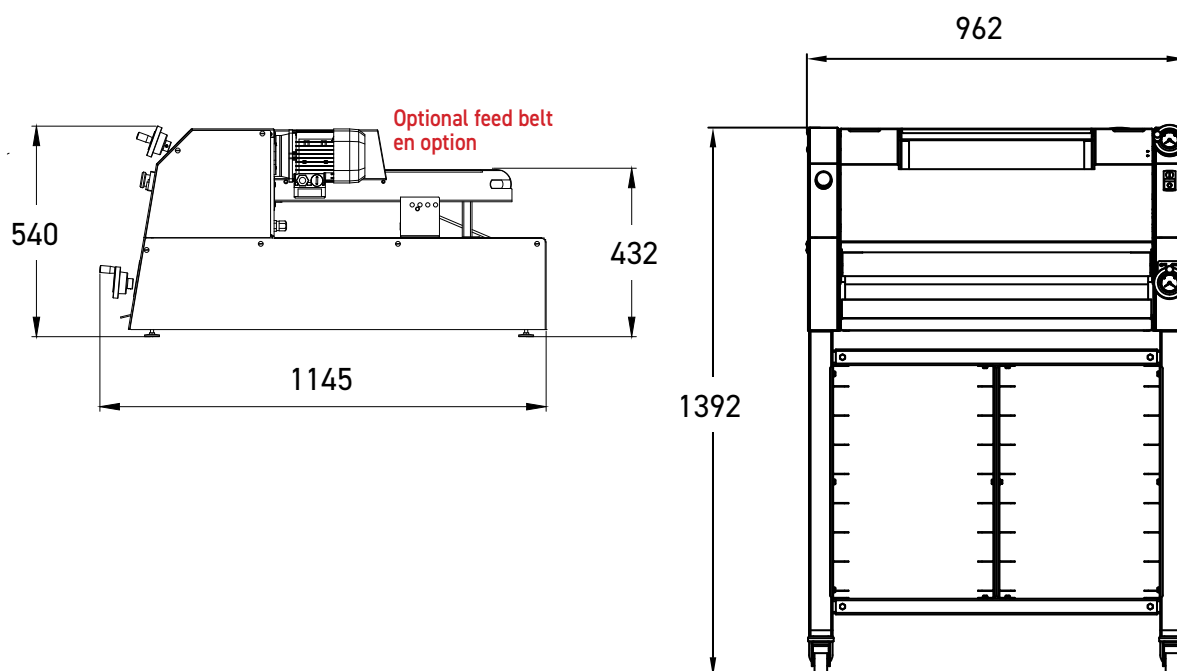



Outfeed table on slides



Easy-to-maintain scrapers



Two food-grade polyethylene rollers



Ergonomic, accurate indicators

Progressive elongation
Thanks to the chain mailReturn table
Self-adjusting according to the size of
the dough pieces.

Option

Pre-elongation module

HF

FEATURES

Min/max weight of dough pieces in grams	50 / 1300
Two food-grade PETP rolling rollers	•
Maximum speed in pieces per hour	1800
Motor power in kW	0.37
Net weight in kg	180

CHOICES

Power supply	230V three-phase 400V three-phase
Left / right controls	on request
Belt type	Wool Wooltop Synthetic

OPTIONS

Pointed end belt	•
Feeding belt	•
Self-contained flour dispenser	•
Pre-elongation module	•
Intake guides	•
NEW Motorised outfeed belt	•