

**Bertrand**



**Marque de sérénité**

# FERMENTOLEVAIN



FL 12 model (to put on a table)



FL 25 model



FL 80 model



FL 140 model

**FERMENTOLEVAIN**  
**LEAVEN PROCESSOR**



# FERMENTOLEVAIN

## The assets of the Fermentolevain:

- + Consistency of quality and taste
- + Rapid development of leaven
- + Perfect, controlled hygiene
- + Simple use and mixing
- + A 100% organic process
- + An economical and profitable product



FL 12 model to put on a table



FL 25 model



FL 80 model



FL 140 model

### ■ Much appreciated bread quality:

Fine gourmets or not, consumers will always love tasty bread. The hand-crafted flavour of a sourdough product is popular as the crunchiness of the crust, irregular air cell structures in the dough and its cream colour give it a more rustic feel, reminiscent of old-style bread.

The loaves obtained are consistent, rich, with a slightly sour taste that can be softened with more «lactic» flavours by adjusting the «starter» used and the temperature.

### ■ Better bread storage:

Generally speaking, sourdough bread is stored better and keeps for longer.

Like a human being who becomes more rapidly dehydrated when he or she perspires, bread dries more quickly when there are many moisture exchanges between the dough and crust.

In the case of sourdough bread, this is considerably reduced. During cooling, for example, it only loses 5% of its weight in moisture, as opposed to an average of around 20% for «conventional» yeast bread.

### ■ Easier mechanisation and working of dough:

Using natural leaven shortens the kneading time.

As the glutinous tissue is much more structured, mechanical operations are easier: cutting is sharper, the dough is less sticky and scarification is simpler.



### ■ FERMENTOLEVAIN : a name that has become part of baking history

In 1994, Bertrand-Puma marketed its first Fermentolevain, thus reproducing the natural bread-making process.

Considered to be revolutionary, this invention offered a new approach to taste and flavours and received the Innovation Trophy at the European trade fair.

Professionals took a keen interest in it, having rapidly understood the advantages it could offer to make an alternative to «industrial» bread. It is a way of resisting standardisation of taste and of focusing on genuine baking know-how.

A «legend» was born and the name Fermentolevain or «Fermento» soon became a reference, even becoming part of the trade's everyday vocabulary.

«With the Fermentolevain, I can control the taste of my bread, save money while making all the difference! «

Some will say that you don't need a machine to make natural sourdough bread... They're right! However, a conscientious professional will strive to obtain a sourdough bread of constant quality and taste in irreproachable hygiene conditions.

### ■ The right quantity, at the right time:

The Fermentolevain range guarantees that your natural sourdough capacity matches your production.

All our Fermentolevain models allow you to keep your basis leaven for several days and produce refreshed leaven in the strictest hygiene conditions.

All of them, even with the smallest bowl capacity have a heating pipe and cooling coil designed to promote maturing and storage of natural sourdough.

You can modulate storage length to adapt to your leaven production and work hours.

### ■ Control the flavour of your bread:

Controlling the development of leaven means controlling the savour and taste of your products.

By adjusting temperatures, you can easily vary the ratio between acetic acid and lactic acid, thus playing with savours and finding what most suits your customers.

For that, our Fermentolevain machines have a cooling coil and heating pipe regulate maturing and storage phases.

### ■ Irreproachable hygiene:

Producing natural liquid leaven of equal and even quality available day after day is good, but not enough.

When we created the first Fermentolevain in 1994, we immediately integrated notions of cleanability and hygiene in its development.

The materials used comply with all food-making requirements: the paddles and scraper in the bowl are, for example, removable and easy to clean.

Finally, the hand spray option is used to easily clean the bowl (available on the FL 80 and 140 models).

### ■ Simplified management:

Storage cycles are easily monitored using clear and intuitive control panels.

You can create your own recipe by adjusting temperature, cycle length and save them in the machine's memory.



1



2



3

**1** The tank is in food-safe stainless steel as are the paddles that are easy to dismantle and do not require specific tools.

**2** A hand spray, available as option on the FL 80 and FL 140 models, allows easy cleaning of the tank, paddles and scraper.

**3** There is an opening to add ingredients directly into the tank or through the retractable sieve. A plexiglas screen allows visual control without jeopardising hygiene. (picturing a FL25 model)



## ■ Technical features:

FL 140 model (mm)

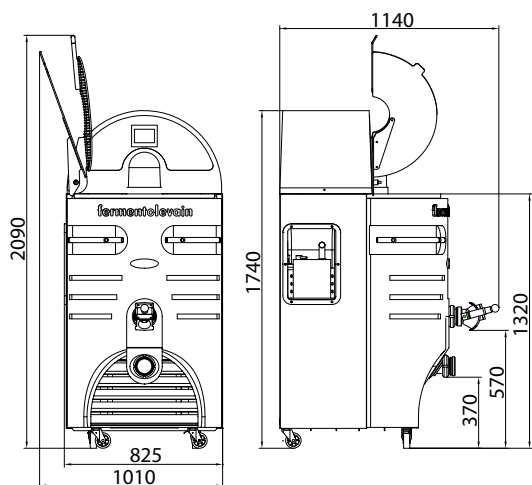

FL 80 model (mm)

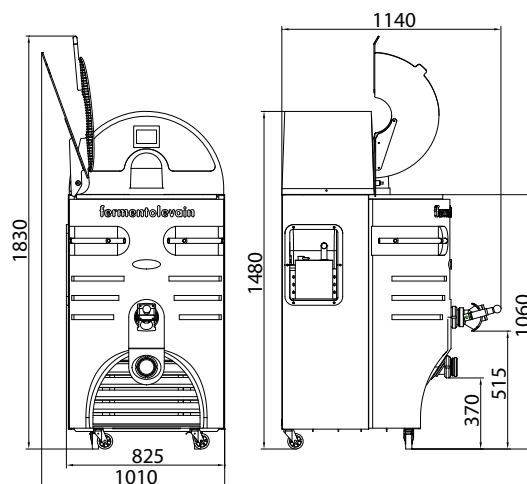

FL 25 model (mm)

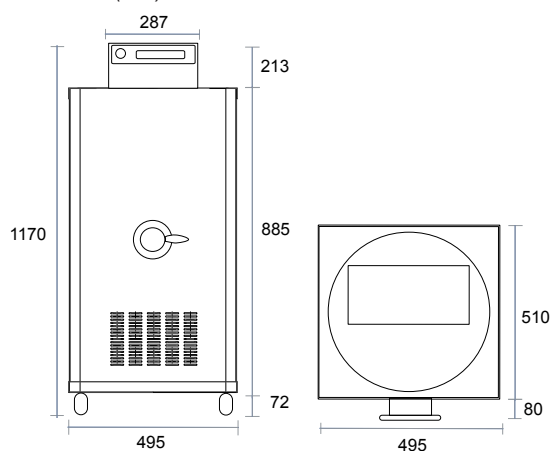

FL 12 model (mm)

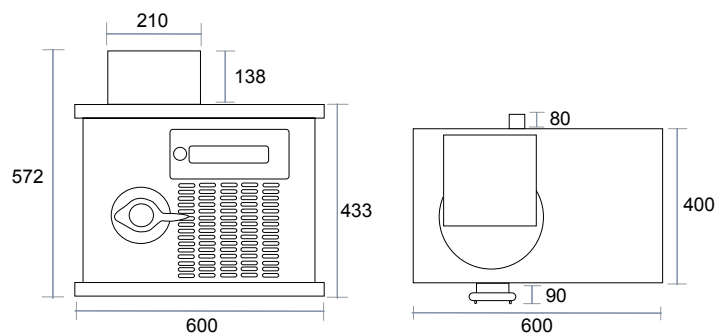

Models	FL 12	FL 25	FL 80	FL 140
Tank total capacity (kg)	12	25	75 kg	125 kg
Tank useful capacity (kg)	10	20	60 kg	100 kg
Weight	25 kg	67 kg	220 kg	265 kg
Electrical power	0,5 kW	0,5 kW	1,3 kW	2,2 kW
Tension	Tri 400+N +T			
Storable recipe	—	—	●	●
Hand spray	—	—	○	○
Basis leaven conservation	●	●	●	●
Alert buzzer	●	●	●	●
Anti-overflowing probe	—	—	●	●
Refrigerating gas	R134 A		R 404 A	

● Standard ○ Options — Non available

BPU 021 - 05/2012 - V00  
Non contractual pictures and illustrations. Bertrand-Puma reserves the right to change and update these information at any time and without prior notice.

BP 54 - Rue Benoît Frachon  
26802 Portes-lès-Valence  
Tél. +33 (0)4 7557 5500  
E-mail : contact@bertrand-puma.fr

